

HEATPUMP & BOREHOLE HEAT EXCHANGER OPTIMIZATION

GROUND MED
24 - 06 - 2010

BESSEL, MADRID

G E O E N E R G Y S Y S T E M S
GROENHOLLAND

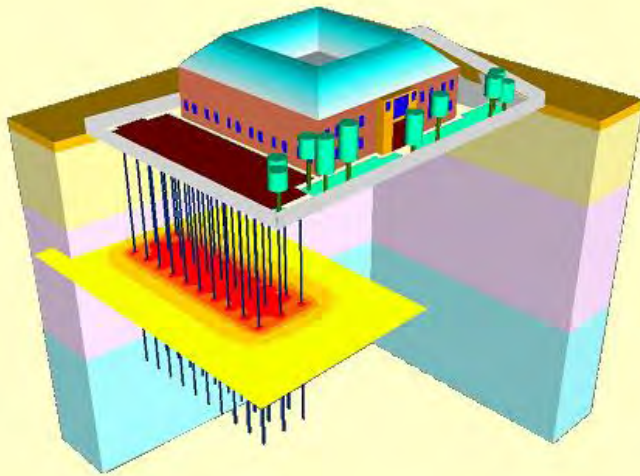

- Consulting
- Thermal building simulation
- Borehole heat exchanger design
- BHE implementation
- Geothermal Response Testing
- Turn-key heat pump systems
- Hybrid heat pump systems

- www.groenholland.com

Dr H.J.L Witte

G E O E N E R G Y S Y S T E M S
GROENHOLLAND

NL OFFICE: VALSCHERMKADE 26; 1059 CD AMSTERDAM; THE NETHERLANDS
UK OFFICE: 22 MANOR CLOSE; HAVANT; HAMPSHIRE; PO9 1BD; UK
WWW.GROENHOLLAND.NL WWW.GROENHOLLAND.COM

G R O U N D M E D

- **Groenholland participates in the Groundmed project:**
 - WP2: High capacity heat pumps
 - WP2: Integrated control & control strategies
 - WP5: System design & borehole heat exchanger optimization
- **Content**
 - Introduction: optimization of heat pump systems
 - How do borehole heat exchangers work
 - Optimization of borehole heat exchangers

GOAL OF A HEAT PUMP SYSTEM

- **Realize savings on primary energy use and greenhouse gas emissions**
 - Efficiency (seasonal efficiency) of the complete system
 - Life-span of the system
 - Maintenance of the system
- **Three Pillars of efficiency and quality:**
 - Good design
 - Good materials
 - Good workmanship and implementation

HOW DOES A HEAT PUMP WORK?

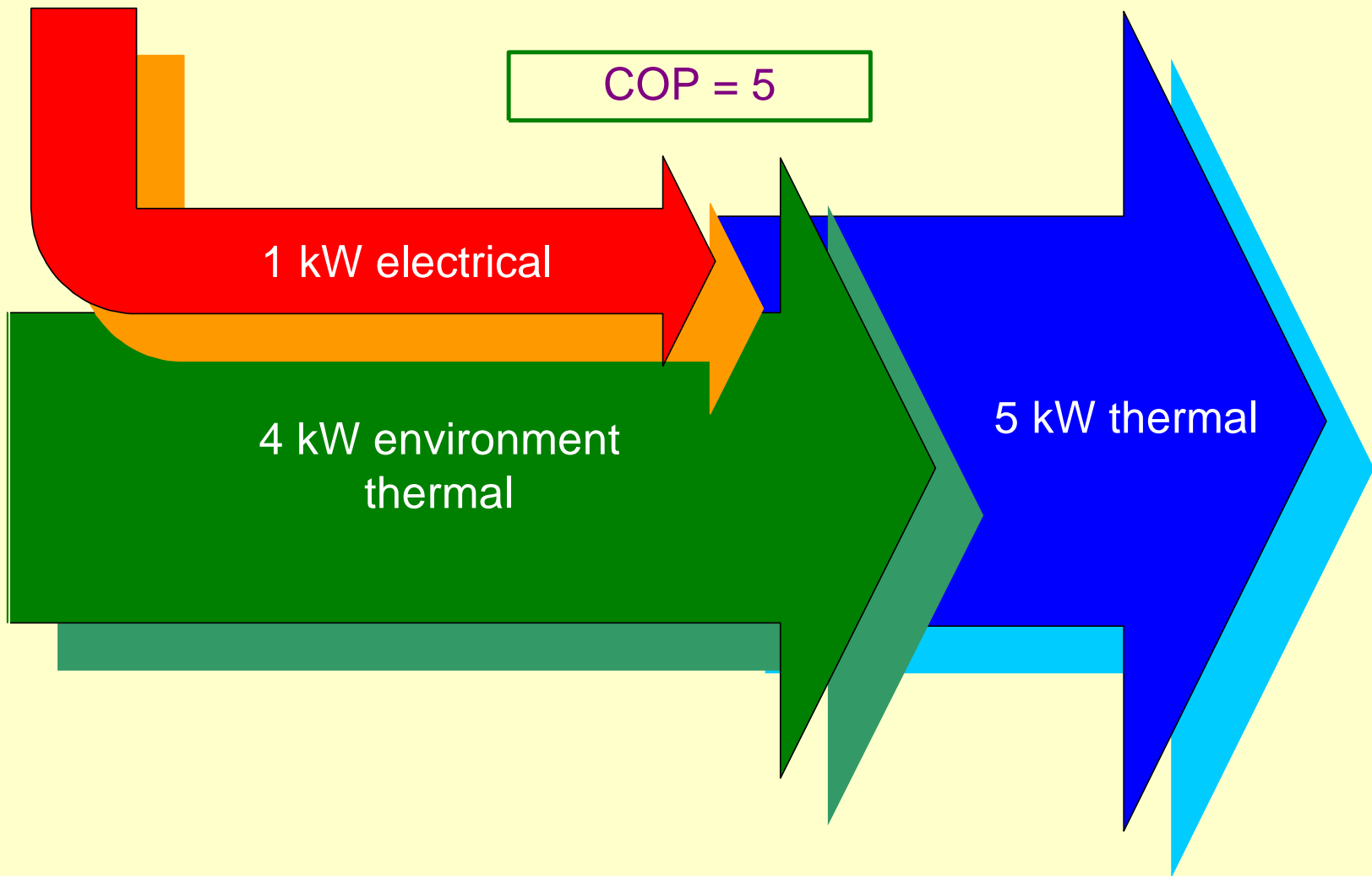

HEAT PUMP SYSTEM EFFICIENCY

- **Some design rules:**

- Select a low temperature for heating (35 - 40 °C)
- Select a high temperature for cooling (8 – 10 °C)
- If possible, use temperature compensated setpoints
- Consider heat pump capacity and capacity steps, consider hybrid system

- Design for a low total heating/cooling load BUT:
- Consider balance between heating and cooling load for the ground source

- Careful hydronic design and pump strategy is needed

- Design BHE for high/low temperature, low pressure loss and low thermal resistance

HEAT PUMP EFFICIENCY: TEMPERATURES

- $$\text{COP} = \frac{H1 - H4}{H2 - H3} = \frac{A}{B}$$

$$\frac{A_1}{B_1} > \frac{A_2}{B_2}$$

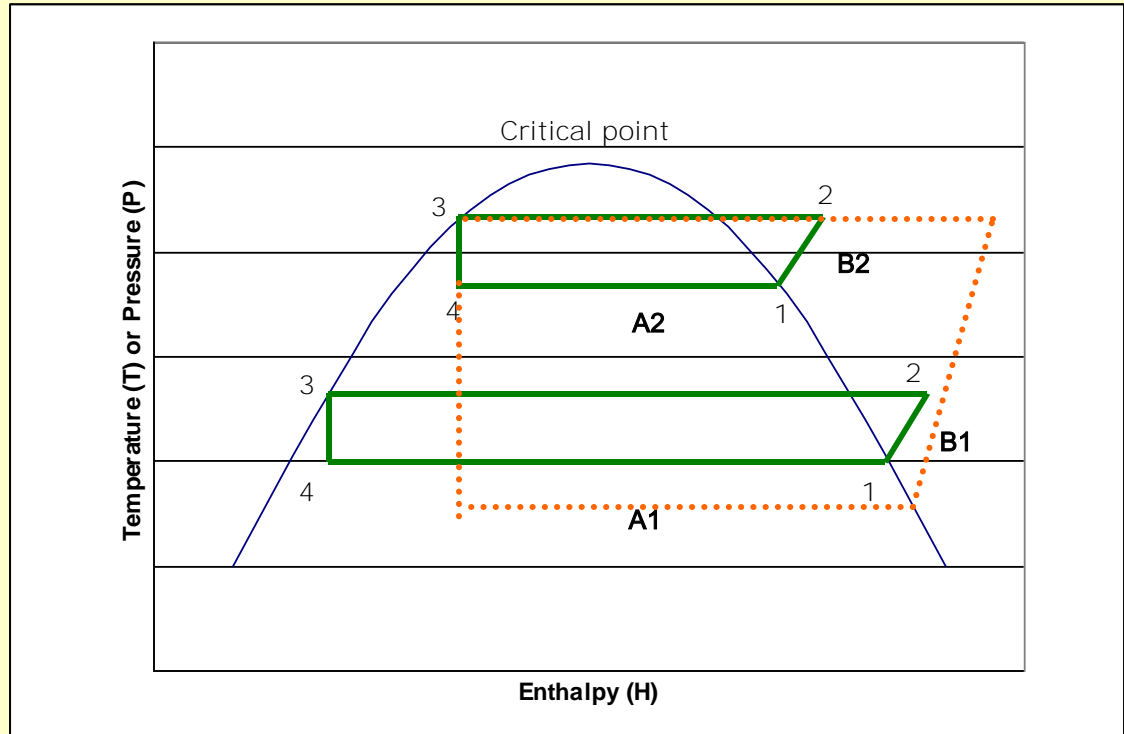

- Even for similar pressure ratios
- Keep temperature low, keep temperature difference small

HEAT PUMP EFFICIENCY: TEMPERATURES

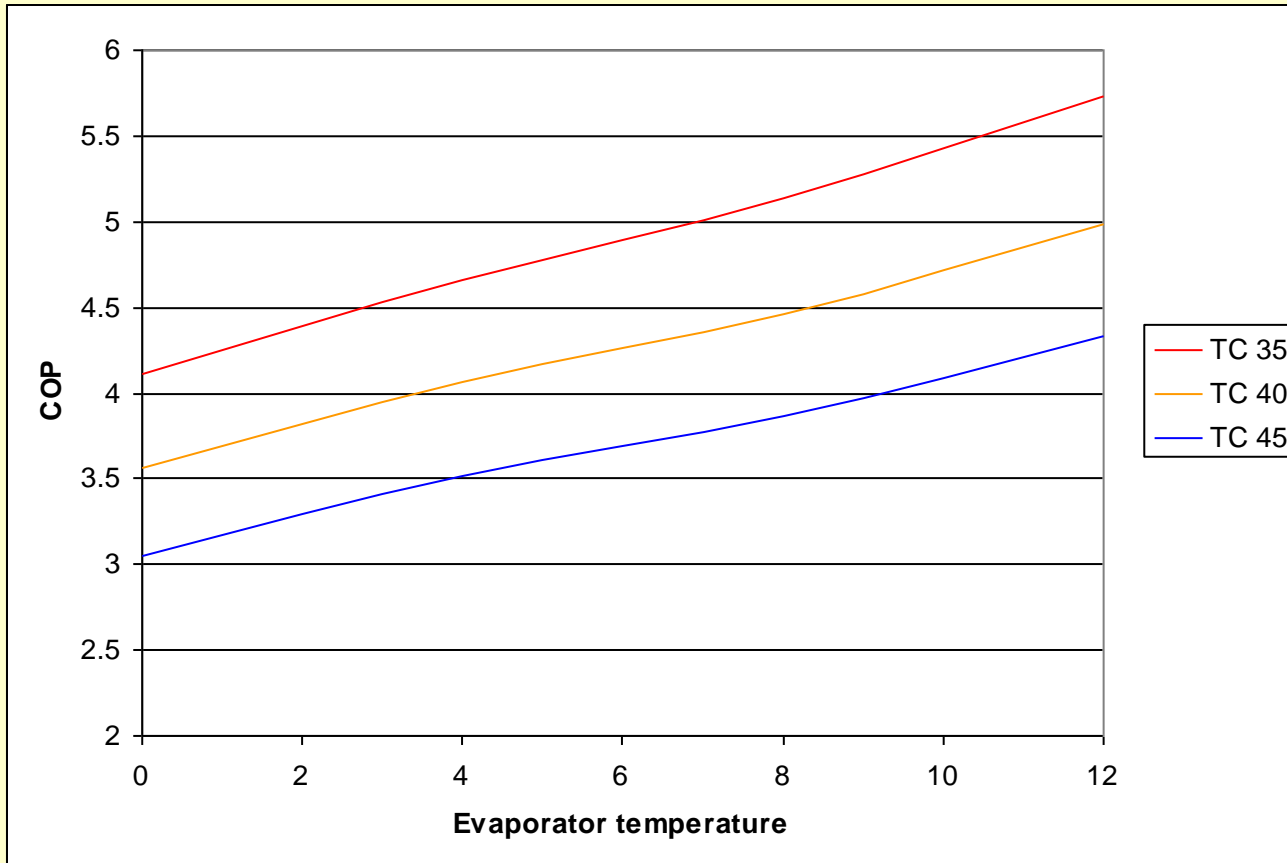

HEAT PUMP EFFICIENCY: CAPACITY

- **A big machine or a small machine?**

- General: with 50% of capacity one can do >80% of load
- Achieve a good balance between peak load and base load

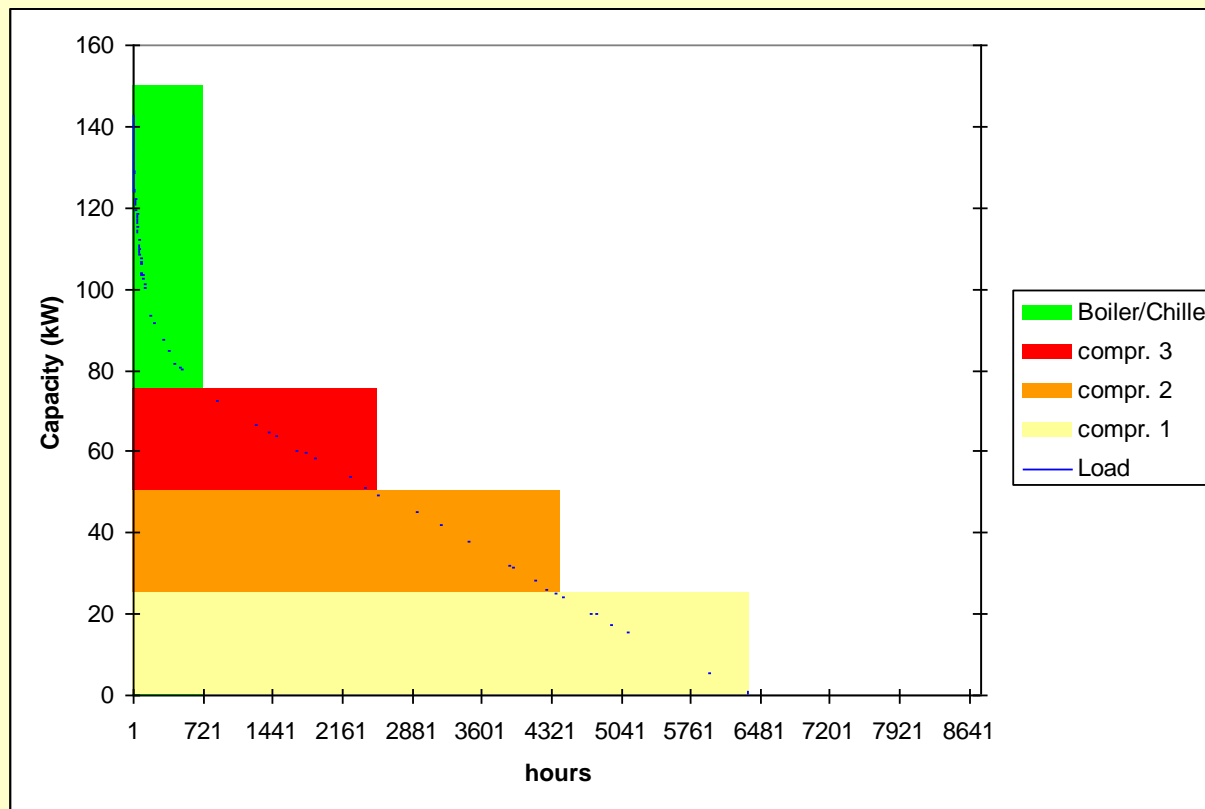

HEAT PUMP EFFICIENCY: LOAD BALANCE

- Sink temperature depends on building system design
- Source temperature depends on ground response, this is coupled to the total energy requirement

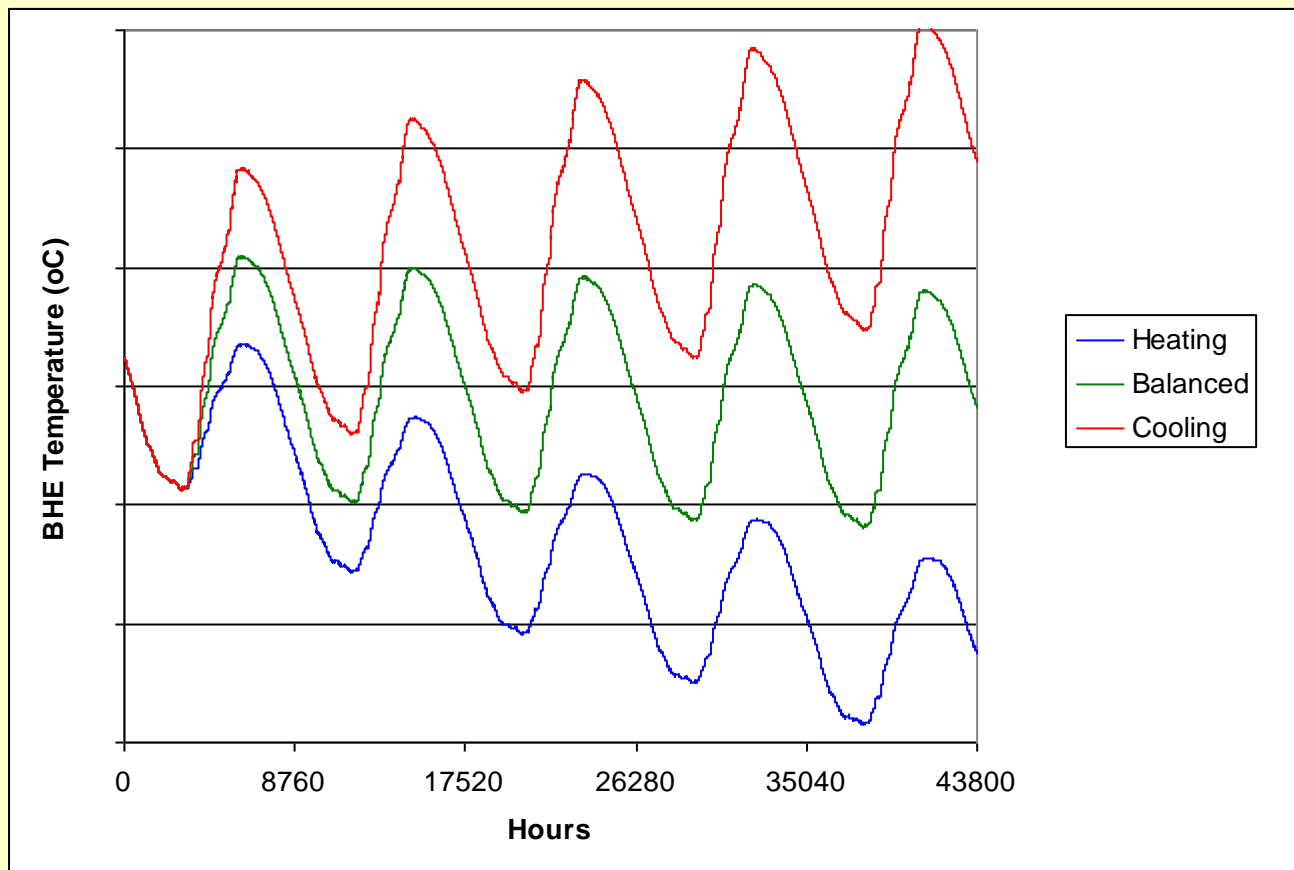

HEAT PUMP EFFICIENCY: PUMPING

- **Pump selection, move a certain amount of water around**
 - Normal building loop: high DT (10K) gives relative low flow
 - For heat pump DT between 5 – 7K: higher flow rates needed
 - Moreover: sometimes anti-freeze used (viscosity): higher DP
- Example:
 - Power requirement difference 1.4 kW (with 2000 running hours 2.82 MWh)
 - For a 60 kW heatpump COP (4.28) would drop to between 3.75 – 3.0

| FLANGE | Q RATED m ³ /hr | MOTOR P2 kW | P2 @ Q10 dP 150 | ETA % |
|--------|-------------------------------|----------------|--------------------|----------|
| TPE-32 | 12.3 | 1.1 | 1.07 | 38.3 |
| TPE-40 | 13.2 | 1.2 | 0.91 | 41.8 |
| TPE-50 | 22.2 | 1.5 | 0.99 | 41.3 |
| TPE-65 | 33.3 | 2.2 | 1.36 | 30.1 |
| TPE-80 | 57.8 | 3.0 | 2.32 | 17.6 |

- Variable speed pump allows tuning (and energy saving)
- Small pumps have lower efficiency
- Do not oversize too much: efficiency drops dramatically (TPE-80)

THE BOREHOLE HEAT EXCHANGER

- **System of tubes in the ground, typical depth 100 – 200 m**
- **Activates a specific soil volume for heat exchanger**
- **Has a specific surface for heat exchange**
- **Heat exchange due to conduction**

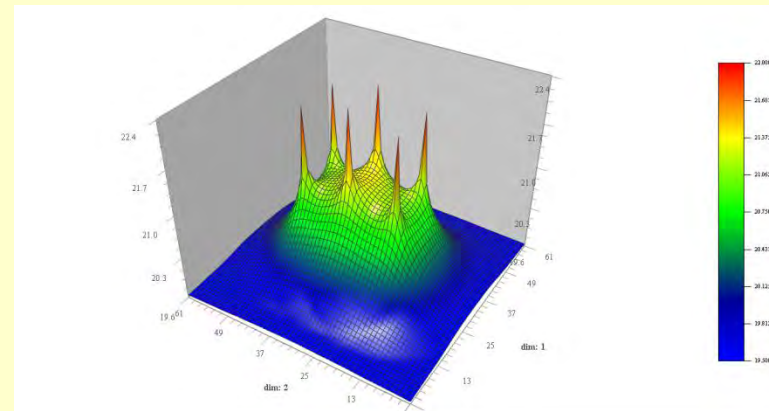
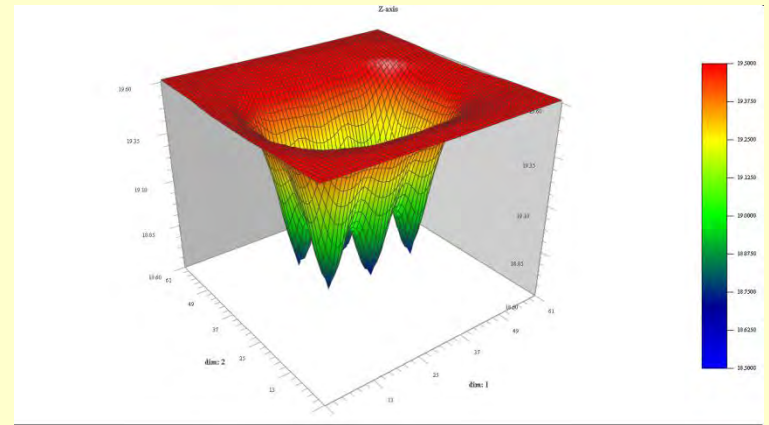
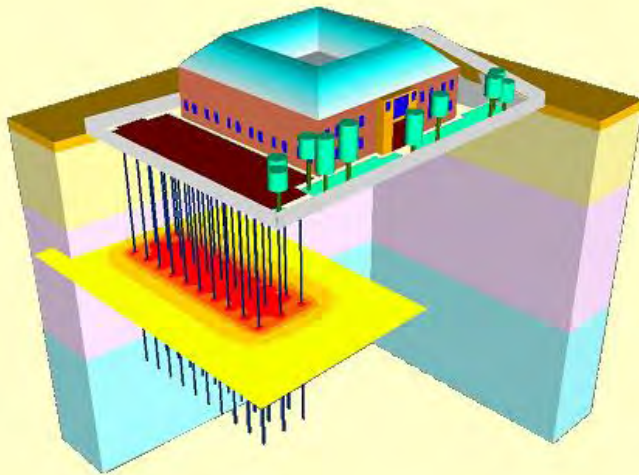

INSTALLING BOREHOLE HEAT EXCHANGER



BOREHOLE HEAT EXCHANGER

- **Monthly / seasonal loading: global response**
 - Spatial dimension meters: to hundreds of meters
 - Time dimension: weeks to many years
- **Main parameters:**
 - Building seasonal loading
 - Ground temperature, thermal conductivity, heat capacity
 - Size (Volume) of the store
- **Daily heat pump cycles**
 - Spatial dimension: centimeters do decimeters
 - Time dimension: minutes to hours
- **Main parameters**
 - Heat pump capacity
 - Borehole construction and heat exchanger design

BHE OPTIMIZATION

- **Heat pump capacity and BHE store size**

- 1A: 300 running hours, 50 kW (15 MWh). Store size 1980 m
- 1B: 2000 running hours, 7.5 kW (15 MWh). Store size 270 m

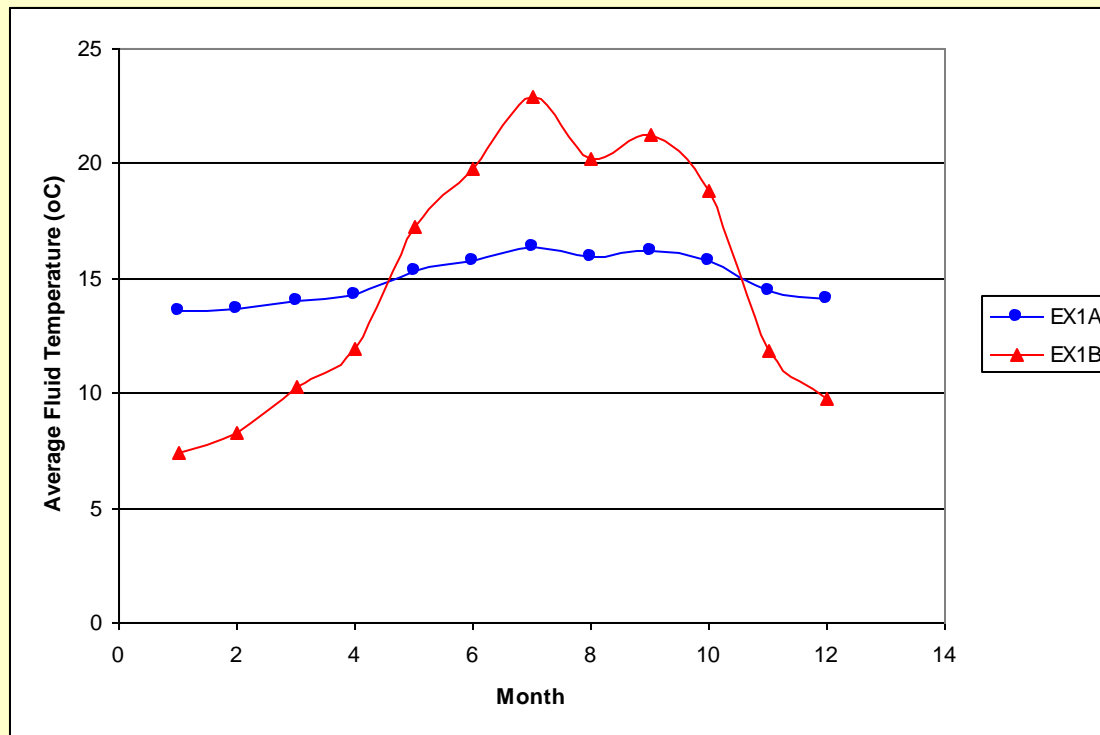

BHE OPTIMIZATION

- **BHE spacing, unbalanced energy profile**

- 5 m spacing with conductivity 1.5 is worst case (100% reference)

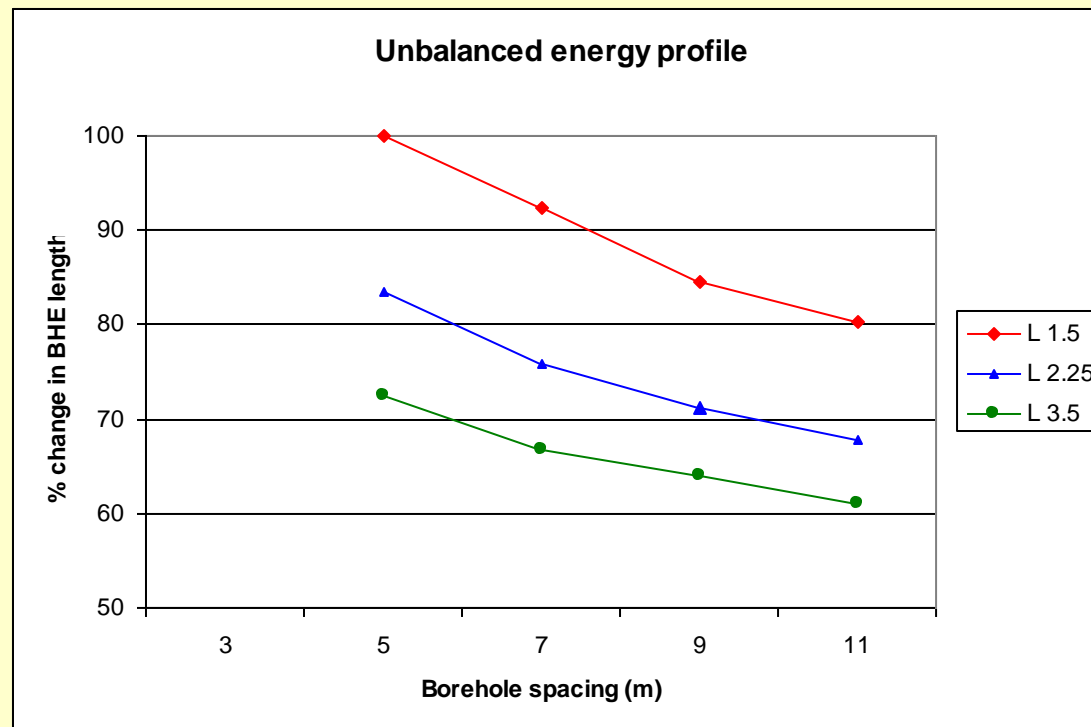

BHE OPTIMIZATION

- **BHE spacing, balanced energy profile**
 - 3 m spacing with conductivity 1.5 is worst case (100% reference)

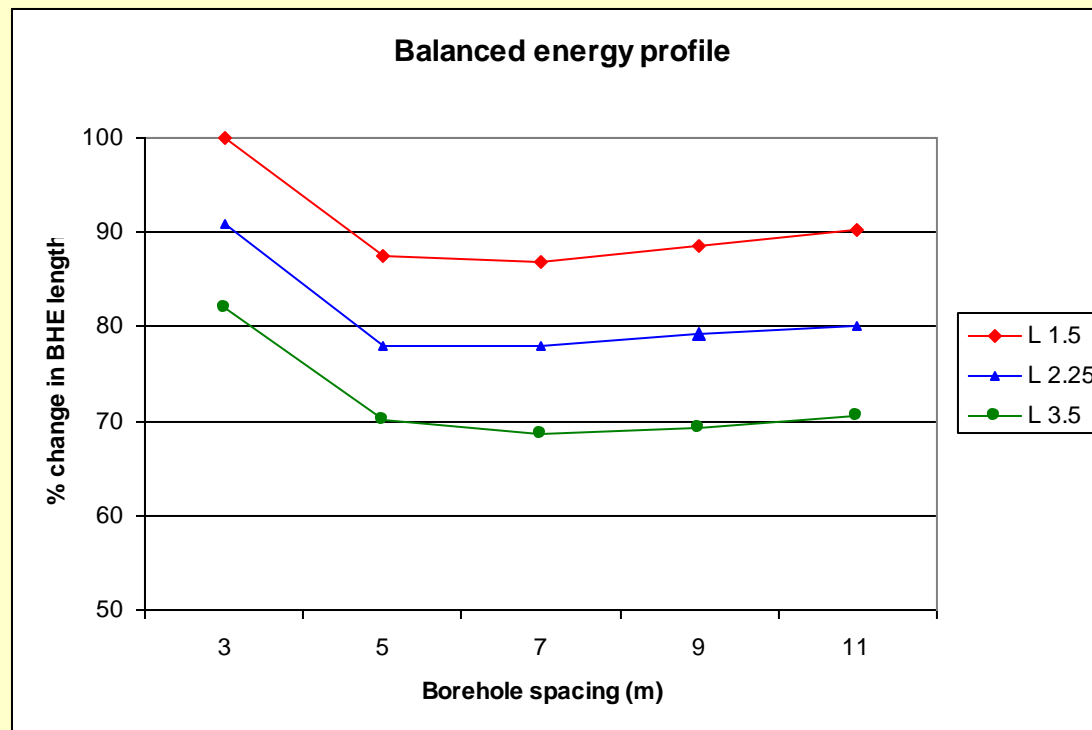

BHE OPTIMIZATION

- BHE size, load balance and store topology

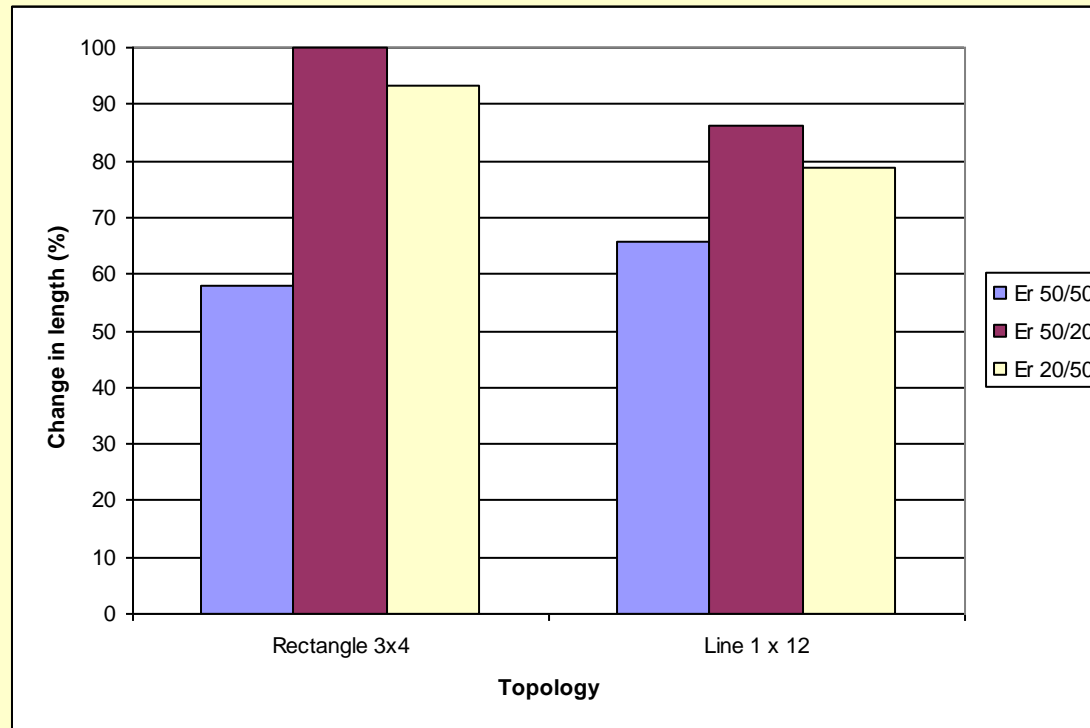

BOREHOLE HEAT EXCHANGER CONSTRUCTION

- **Single U-loop, double U-loop, concentric**
- **Borehole and borehole filling material**
- **Tube dimensions and spacers**

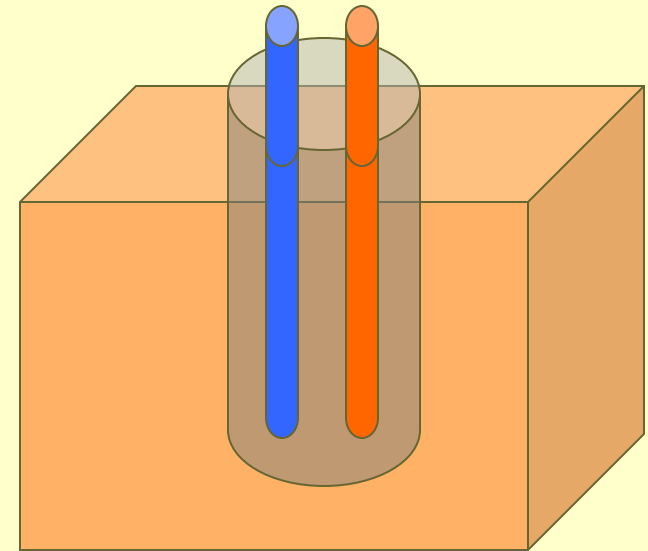
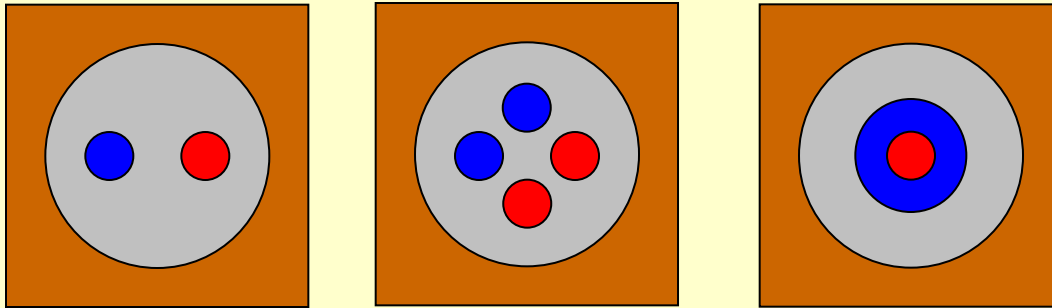

- **Fluid flow in pipe: turbulent / laminar**
- **Pipe geometry**
- **One general parameter: Thermal Borehole Resistance R_b**
- **Higher R_b = bigger potential (Temperature difference) needed**

BHE OPTIMIZATION

- **Effect of Rb on temperature gradient and COP**
- **Rb, specific heat extraction rate and DT are related:**
- **DT = Rb * HR**
- **General: 3% lower COP per K**

| Rb (K/(W/m)) | Temperature gradient (K) for heat rate (W/m) | | | Percentage lower COP for heat rate (W/m) | | |
|-----------------|--|-----|----|--|------|----|
| | 30 | 40 | 50 | 30 | 40 | 50 |
| 0.08 | 2.4 | 3.2 | 4 | 7.2 | 9.6 | 12 |
| 0.12 | 3.6 | 4.8 | 6 | 10.8 | 14.4 | 18 |
| 0.16 | 4.8 | 6.4 | 8 | 14.4 | 19.2 | 24 |
| 0.20 | 6 | 8 | 10 | 18 | 24 | 30 |

BHE OPTIMIZATION

- Relation between flow and R-fluid pipe
- Higher flow rate = lower resistance
- Higher flow rate = bigger pressure loss

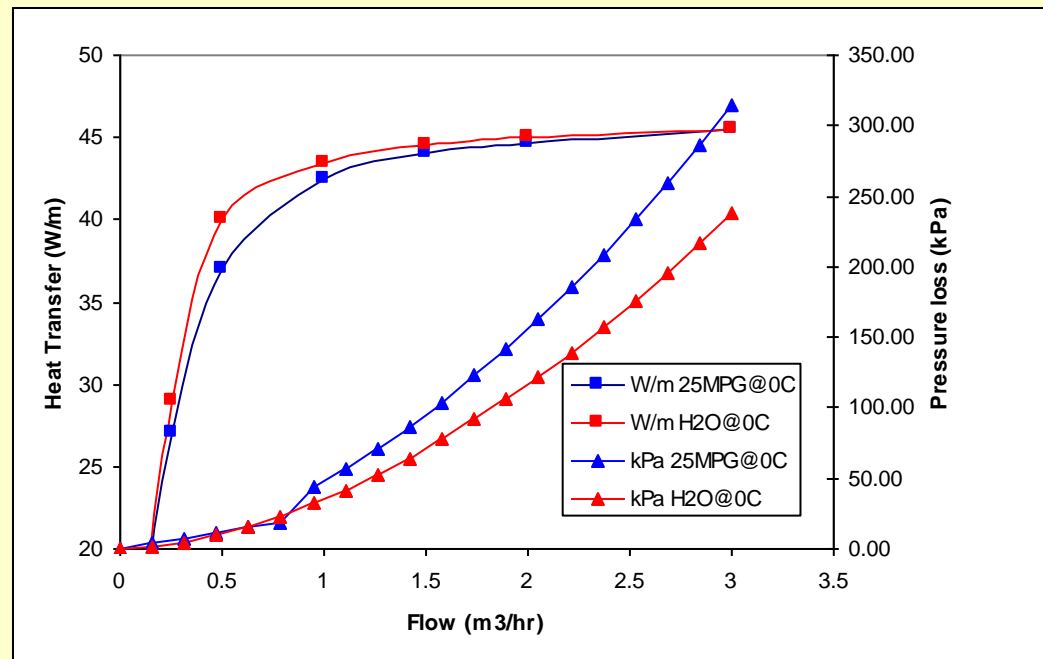

BHE OPTIMIZATION

- Borehole construction parameters

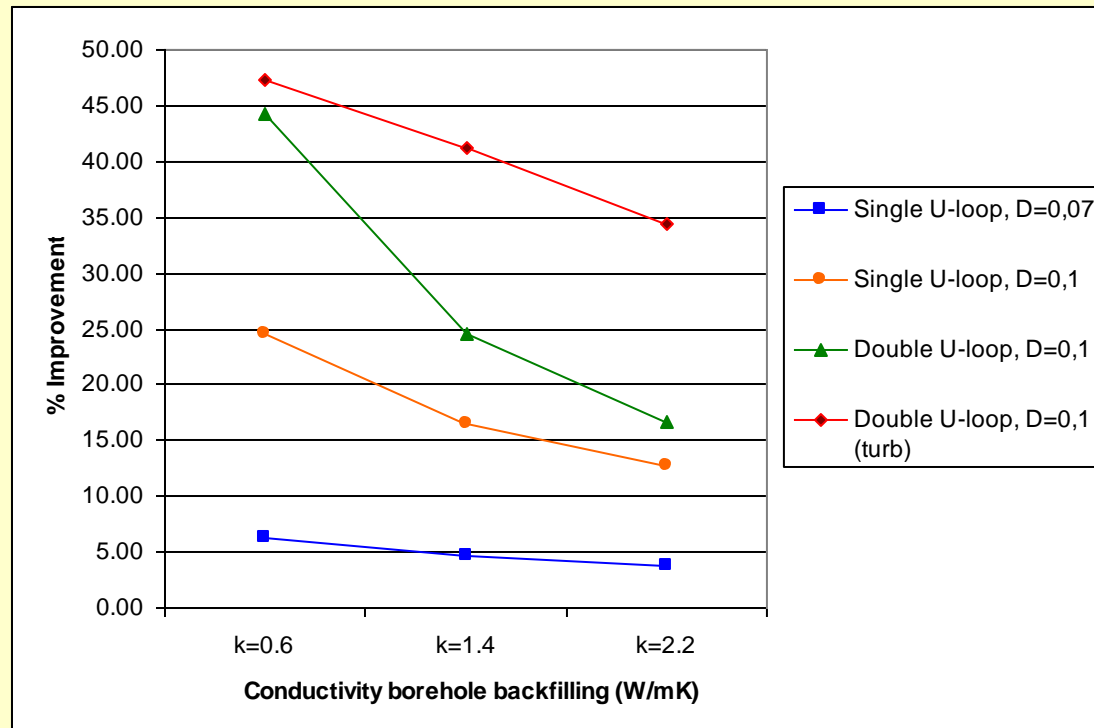

BHE Dynamical Model

- **TRNSYS, basic Borehole model SBM (will be changed later)**
 - Load matching heatpump (type 903)
 - Temperature compensation possible
 - Pressure loss calculations for pipes, U-pipes and concentric HX (type 906)
 - Temperature and concentration dependent fluid properties (type 907)
 - Borehole resistance model (type 908)
 - SBM parameter writer (type 909)

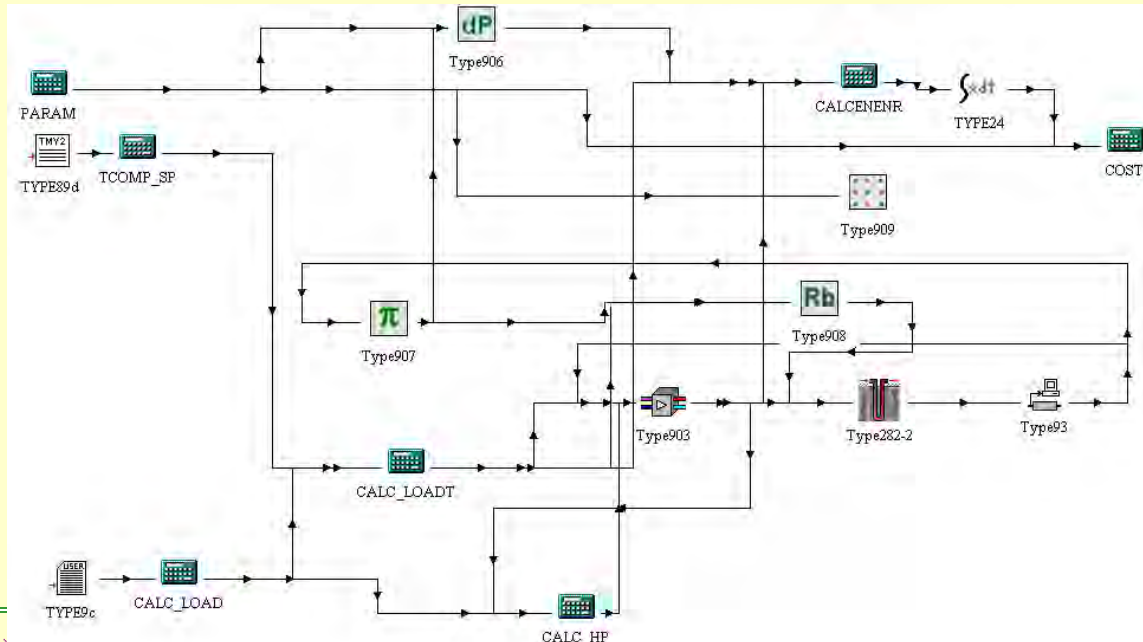

RESULT 1: R B Sensitivity

- **With the model studied parametrically Rb (Ra, Rb and Rb-eff) and pressure loss**
- **Pipe diameter 0.032 (fixed), roughness 0.01 (fixed)**
- **Circulation medium: Water @ 20 oC 30% MPG @ -5 oC**
- **Length BHE: 50; 100; 150; 200 meters**
- **Diameter BHE: 0.12; 0.17; 0.22 m**
- **Shank spacing 0.05; 0.075 0.10 m**
- **Pipe conductivity 0.2; 0.4; 0.6 W/mK**
- **BHE conductivity 0.5; 1.5; 2.5 W/mK**
- **Soil conductivity 0.5; 1.5; 2.5 W/mK**
- **Flow 0.1; 0.6; 1.1, 1.6 m3/hr**

RESULT 1: R B Sensitivity

- Laminair/turbulent flow one of the main effects
- Other parameters partitioned
- Min. Rb-eff 0.057, Max. 1.50

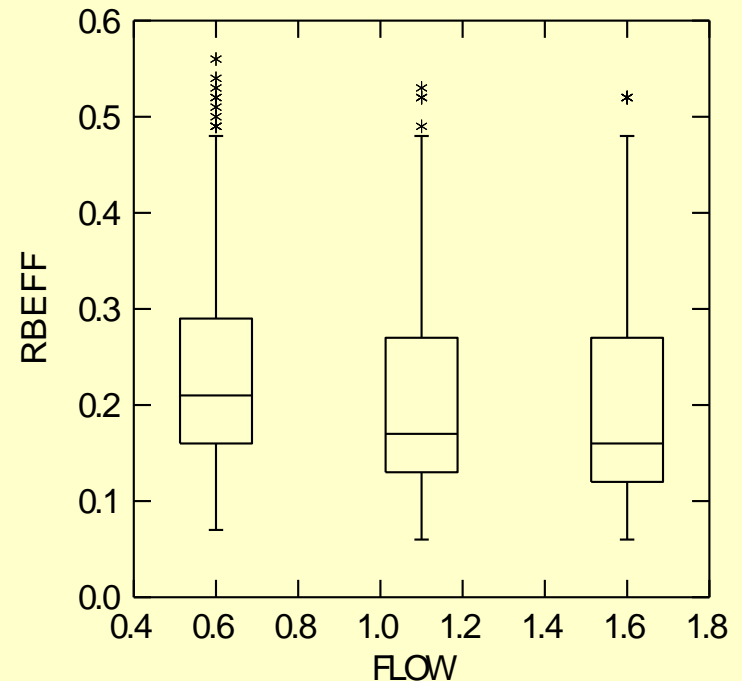
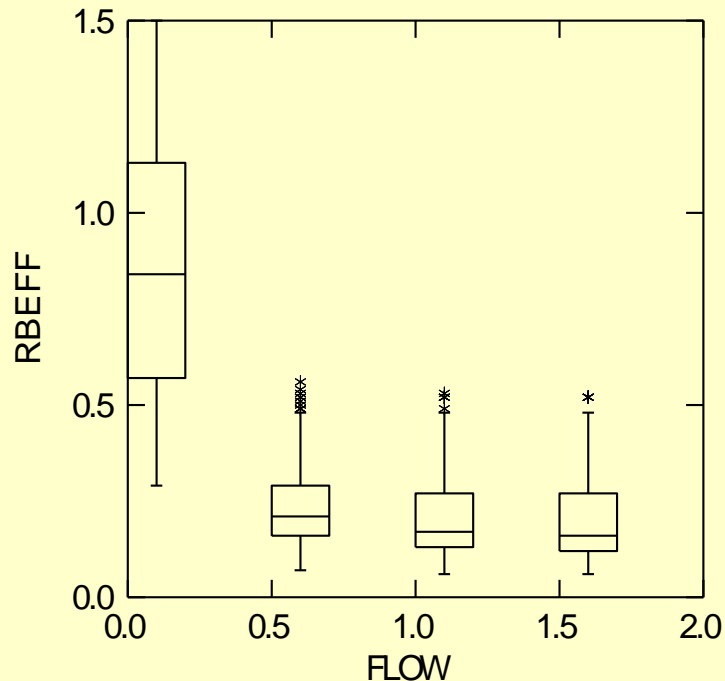

RESULT 1: R B Sensitivity

- **Rb is more sensitive to length for laminar conditions**
 - Due to correction term fluid variation along borehole wall
 - Check with solution based on uniform heat flux

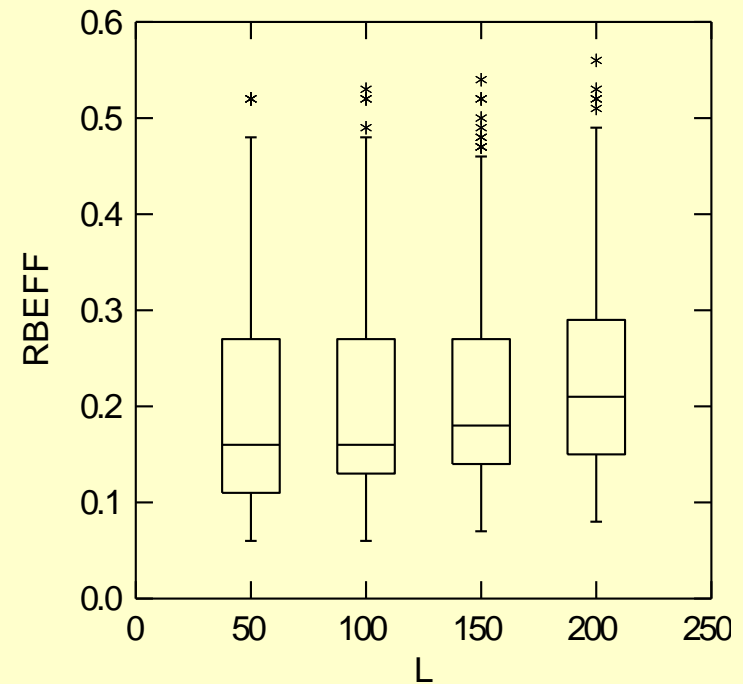
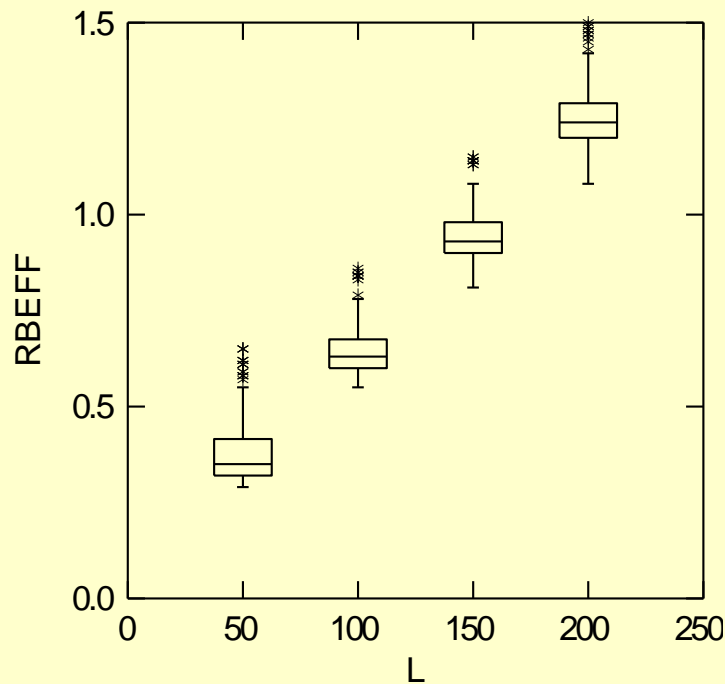

RESULT 1: R B Sensitivity

- **Borehole diameter with turbulent flow**

- Smaller is better, but take into account backfill conductivity

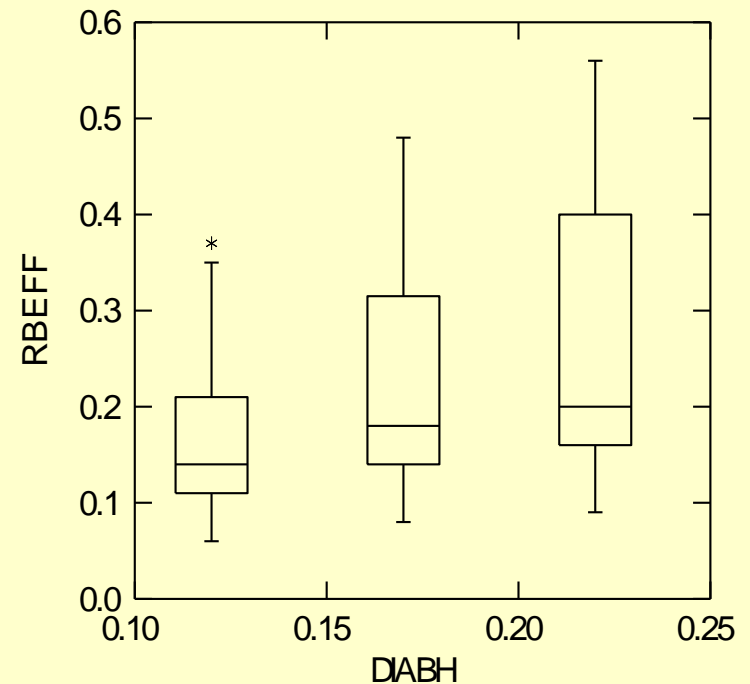
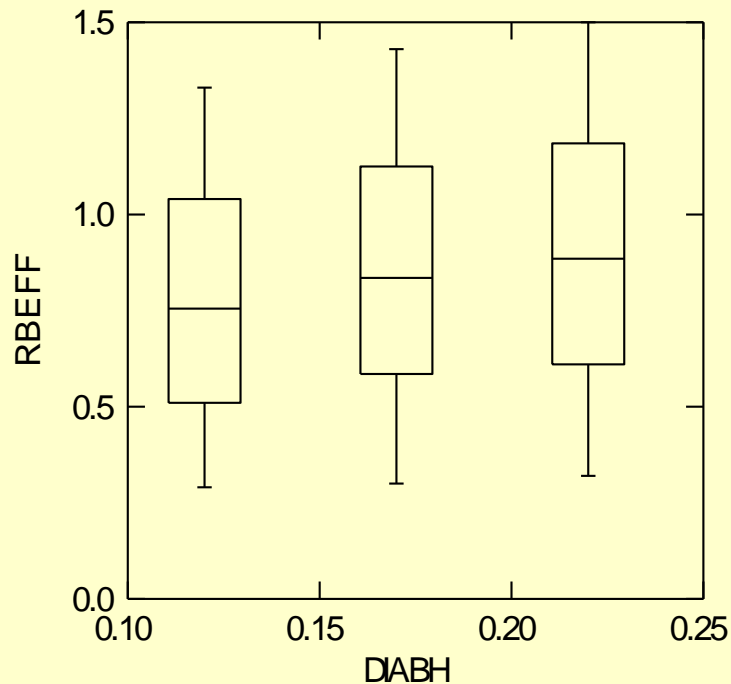

RESULT 1: R B Sensitivity

- **Borehole conductivity main effect with turbulent flow**
 - Take into account effects of borehole diameter and SHANK

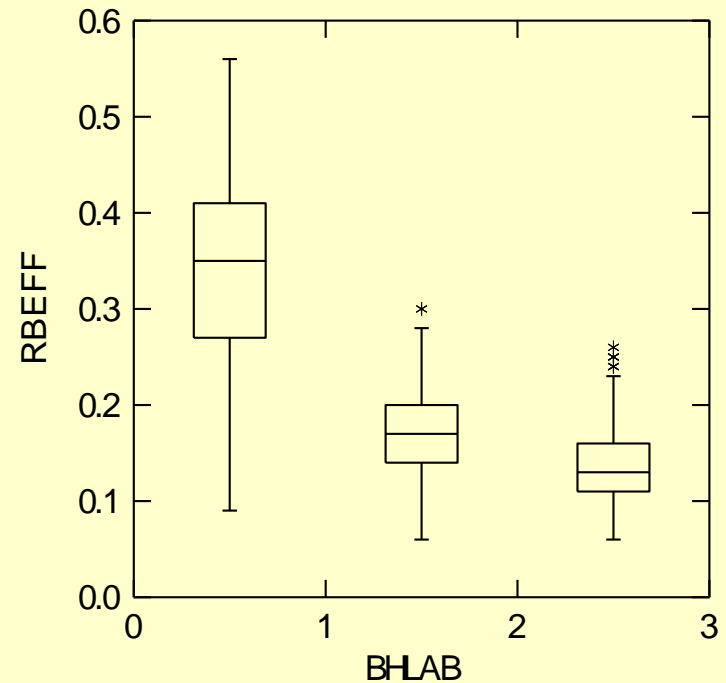
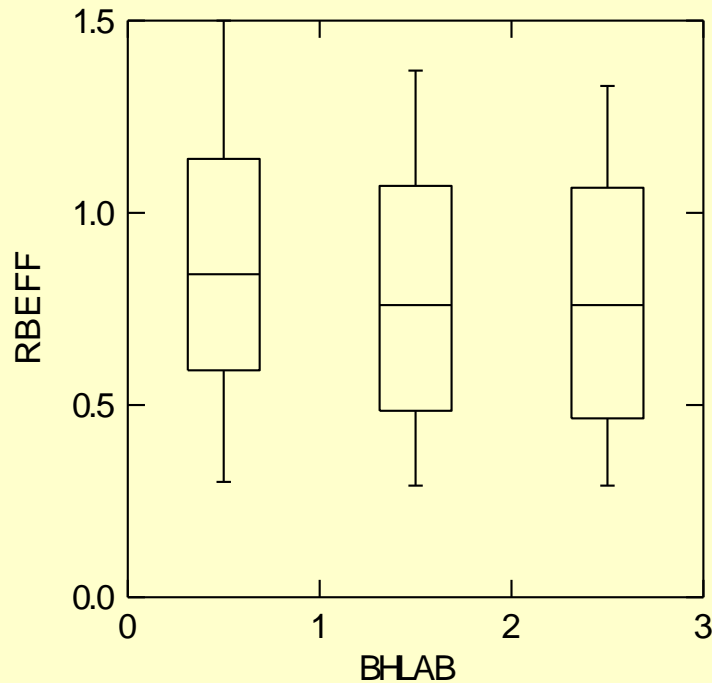

SOME RECOMMENDATIONS

- **Small capacity heat pump**
 - Building design...
 - aim for 1500 – 2000 FLH heating, 750 – 1200 FLH cooling
- **Balanced energy profile preferred**
- **Low temperature heating, high temperature cooling**
- **Small circulation pump (for larger system staged pump)**
- **Water is preferred as circulation medium**
 - Consider startup month in systems with heating/cooling load!
- **2300 < Reynolds < 10.000 (water) | < 3000 (30% MPG)**
- **If Re < 2300, shorter BHE may be better**
- **Use high conductivity grout material**
 - Only use bentonite mix when required by law or geo-hydrology
- **Large shank spacing preferred**
- **Small diameter borehole preferred**